

BALLASTED ROOF MOUNT

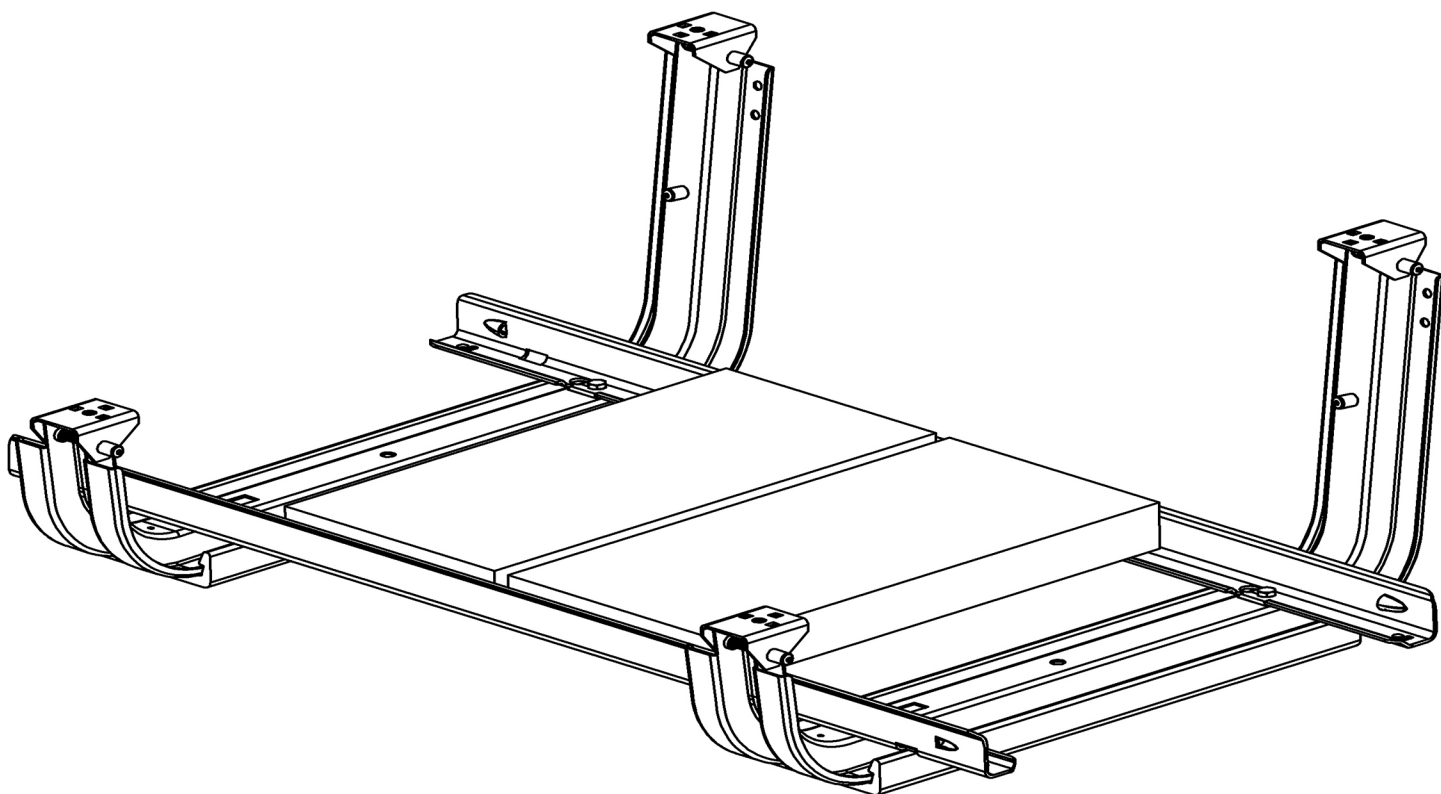

CONTENTS

DISCLAIMER	1
CHECKLIST	2
1. PREPARE TRAYS	3
2. MARK LAYOUT	3
3. CLAMP MODULES	4
4. MANAGE WIRES	5
5. PLACE DEFLECTORS	5
6. LOAD TRAYS	6
7. COMPLETE ARRAY	6
EW WIRE CLIP (OPTIONAL)	7
MICROINVERTER BRACKET (OPTIONAL)	7
SEISMIC ANCHOR (OPTIONAL)	7
HIGH WIND DEFLECTOR KIT (OPTIONAL)	8
ROOF PADS (OPTIONAL)	8
UNDER-MOUNTING TRAYS (OPTIONAL)	8
WARRANTY	9

DISCLAIMER

This manual describes the proper installation procedures and provides minimum standards required for product reliability and warranty. Thoroughly understanding this manual is imperative to proper installation; failure to follow the guidelines set forth can result in property damage, bodily injury, or even death.

IT IS THE INSTALLER'S RESPONSIBILITY TO:

- Comply with all applicable local or national building codes, including any that may supersede this manual.
- Ensure all products are appropriate for the installation, environment, and array under the site's loading conditions.
- Comply with all of roofing manufacturer's warranty terms, ensuring that any loose debris potentially obstructing installation procedures is removed from the installation area.
- Use only IronRidge parts or parts recommended by IronRidge; substituting parts may void any applicable warranty.
- Ensure safe installation of all electrical aspects of the array. All electrical installation and procedures should be conducted by a licensed and bonded electrician or solar contractor. All work must comply with national, state and local installation procedures, product and safety standards.
- Comply with roofing manufacturer's warranty terms including: using protective barriers between mounting and roofing and roof penetrations and removing all loose debris or gravel prior to installation.
- Ensure that the installation is completed properly and by a licensed solar professional.
- Review the [Engineering Design Guide](#) and [Certification Letters](#) to confirm any engineering specifications.
- Comply with all applicable fire codes including, but not limited to, keeping walkways clear and avoiding obstacles.
- Ensure provided information is accurate. Issues resulting from inaccurate information are the installers' responsibility.
- Verify that the roof slope (or pitch) does not exceed 5° and that the change in elevation (or height) between adjacent Ballast Trays does not exceed three (3) inches.
- Confirm with the selected module manufacturer that the mounting is compatible with the selected module. Please consult module manufacturer's installation guidelines in order to verify mounting compatibility.
- Verify that proper ballasting has been installed per site specific PE approved engineering drawings.
- Select and source the solid concrete ballast blocks. It is recommended that these solid concrete blocks have a minimum compressive yield strength of 3000 psi or greater OR comply with ASTM Designation C1491.
- Periodically check their installation and make adjustments as needed as the blocks could shift or disintegrate. It is also recommended that an industrial adhesive be used between ballast blocks when stacking.

CHECKLIST

PRE-INSTALLATION

- Plan project with a Professional Engineer, reviewing the [Engineering Design Guide](#) and [Design Assistant](#).
- Determine the roofing manufacturer and schedule any necessary inspections prior to beginning installation.
- Acquire any necessary approval for solar and seismic anchor installations from the roofing manufacturer.
- Verify module compatibility with Ballasted Roof Mount.
- Verify that needed components have been obtained. Contact your local distributor for any additional parts.
- Verify required ballast is acquired. Block sizes should be: 4" x 8" x 16" and 2" x 8" x 16" (3000 psi).

TOOLS REQUIRED

- Cordless Drill (non-impact)
- 7/16" Socket
- 3/8" Socket
- Torque Wrench (0-240 in-lbs)
- Spacer Jig (provided)

TORQUE VALUES

- Ballast Trays Bolts (1/4"-20): 84 in-lbs (dry)
- Module Clamps Bolts (1/4"-20): 120 in-lbs (dry)
- Mounting Plates Bolts (1/4"-20): 84 in-lbs (dry)
- Grounding Lugs Nuts (1/4"-20): 120 in-lbs (dry)
- Grounding Lugs Set Screws (1/4"-20): 84 in-lbs (dry)
- Wind Deflectors Nuts (1/4"-20): 84 in-lbs (dry)
- High Wind Deflector Kit Screws (1/4"-14): Snug
- Microinverter Bracket Nuts (1/4"-20): 120 in-lbs (dry)
- Seismic Anchor Nuts (1/4"-20): 204 & 120 in-lbs (dry)
- Reduce torque values by 15% when lubricated.

PRIMARY COMPONENTS

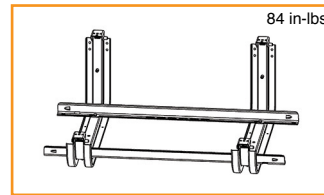

Ballast Trays
Galvanized Steel

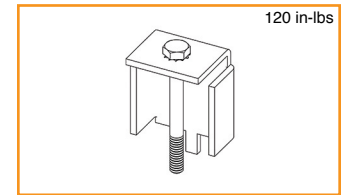

Module Clamps
Aluminum

SECONDARY COMPONENTS

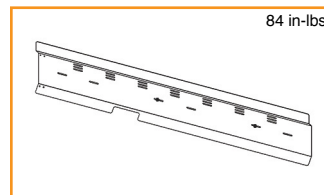

Wind Deflectors
Aluminum

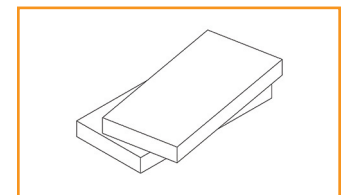

Ballast Blocks
Concrete

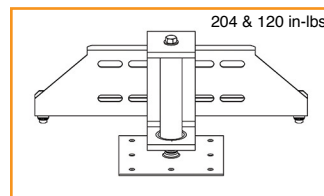

Seismic Anchors
Steel & Aluminum

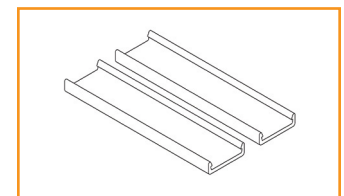

Roof Pads
Rubber

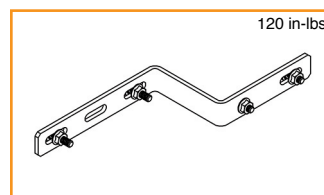

Microinverter Brackets
Aluminum

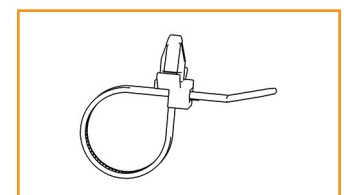

EW Wire Clips
Coated Nylon

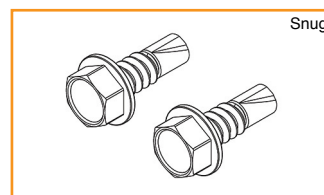

High Wind Deflector Kit
Stainless Steel

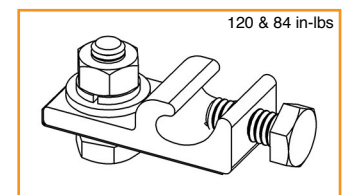

Grounding Lug
Tinned Copper & SS

1. PREPARE TRAYS

A. ASSEMBLE TRAYS

Set down two (2) Main Supports, then fit two (2) Ballast Supports into slots. Ensure tabs are fully inserted into slots. Torque the four (4) 1/4"-20 hex bolts to 84 in-lbs.

- ☑ Do not use impact drills, as bolts may break. Use a slow drill speed to reduce hardware from seizing up.
- ☑ If using Roof Pads, attach to bottom of Main Supports at this time. See [Page 7-8](#) for installing optional components.

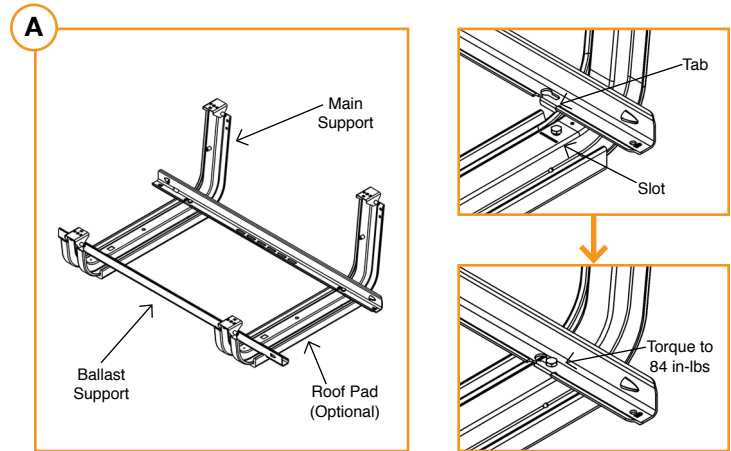

B. MODULE CLAMPS

Install included WEEB Clip on each Mounting Plate. Make sure O-Rings are rolled up bolts to support Module Clamps. Loosely place a Module Clamp on each Mounting Plate by engaging the first few bolt threads, leaving a 1/4" gap between Module Clamp and Mounting Plate.

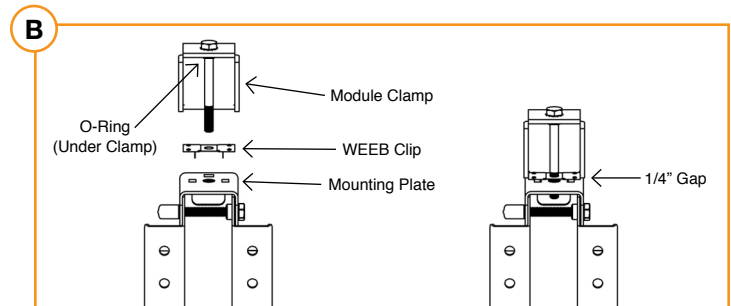

2. MARK LAYOUT

A. MARK LINES

Locate southern edge of array and chalk Baseline, east-west. Locate center of Baseline and chalk perpendicular Centerline, north-south.

- ☑ Baseline and Centerline should extend full distance of array, to ensure array stays aligned as it is built.

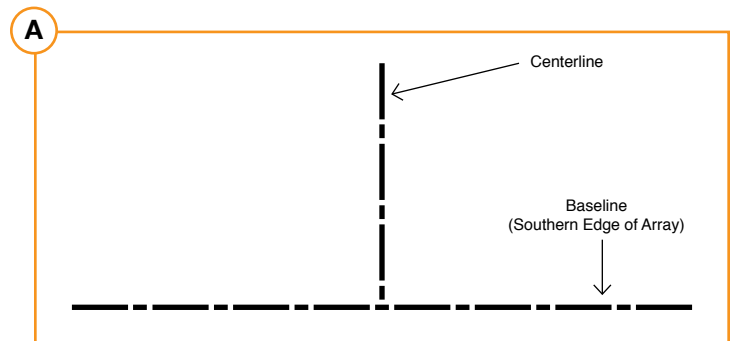

B. TRAYS LOCATIONS

From Centerline, work toward sides of array. Place marks along Baseline, equal to module length plus 3/8". At each side of array, mark 16" back towards Centerline.

- ☑ To speed up marking process, create a "story stick" equal to the module length plus 3/8" as a spacing reference.

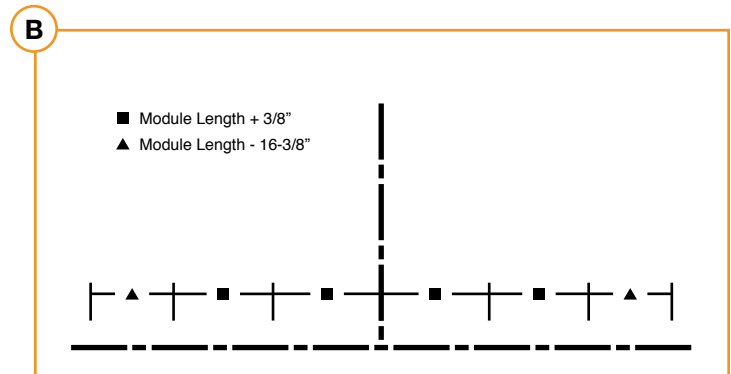

3. CLAMP MODULES

A. PLACE TRAYS

Place trays, aligning center notch with marks on Baseline. Put one full Ballast Block in each tray until entire row is complete. Place next row above previous row.

- ☑ Row spacing is roughly equal to module width plus 20".
- ☑ See [Page 8](#) for optional under-mounting procedures, to hide trays under modules on edges of array.

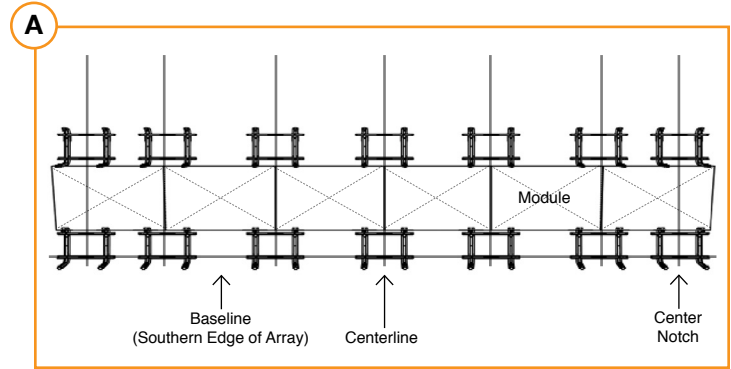

B. SET MODULES

Starting from Centerline, east or west, place first module into Module Clamps with one clamp from each tray. Module ends should be 12" from center of Module Clamps.

- ☑ Use provided Spacer Jig as a spacing reference.

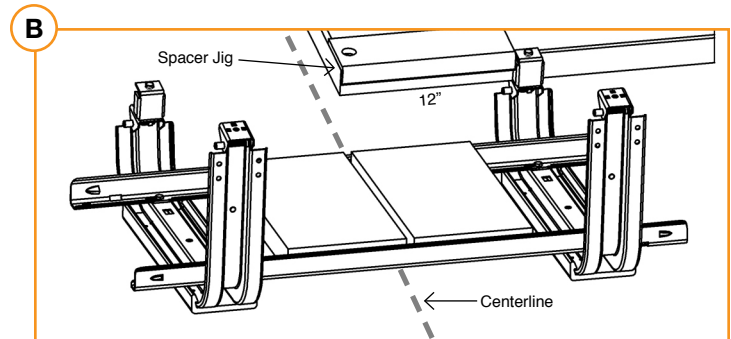

C. SECURE MODULES

Starting with lower (southern) Module Clamps, torque bolts to 120 in-lbs. Do not use impact guns for installation.

- ☑ While tightening, use one hand to pull underside of module snug, making sure frame is fully engaged and sitting on WEEB Clips.
- Torque Mounting Plate to 84 in-lbs. Repeat for remaining Module Clamps. Do not move Ballast Trays after clamping.
- ☑ Use Spacer Jig to align system as installed. Use 3/8" thickness of Spacer Jig to properly space modules.
- ☑ When placing last module at ends of rows, use short side of Spacer Jig to space edges of modules 4" from center of clamps.

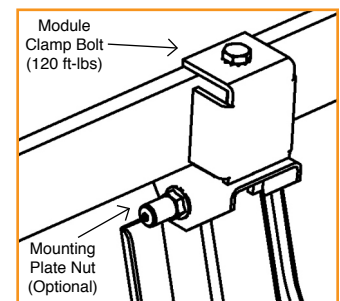
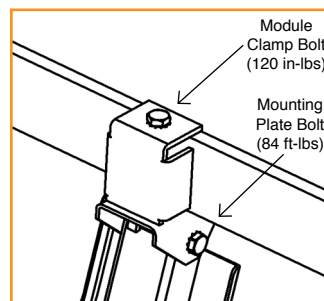
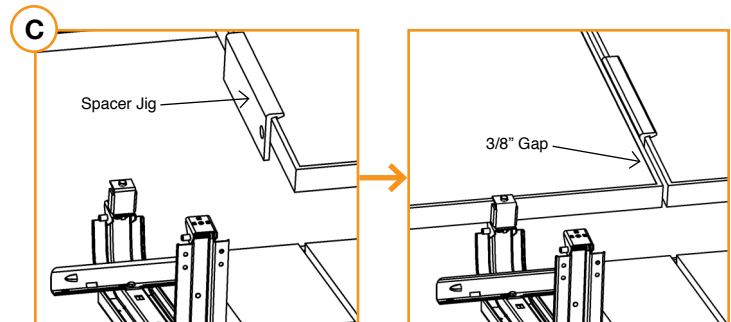

REPEAT STEPS A, B, & C

Place Ballast Trays, set modules onto Mounting Plates, and secure modules for all rows.

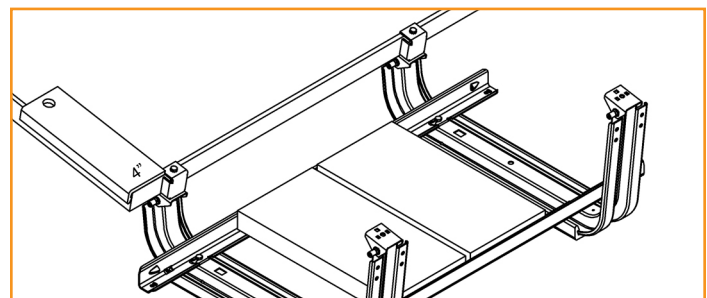

4. MANAGE WIRES

A. MODULE WIRING

Perform the module-to-module wiring and string wiring as recommended and required by local jurisdictions.

- ☑ If using Wire Clips to manage wiring, see [Page 7](#).
- ☑ If using Microinverter Brackets, see [Page 7](#).

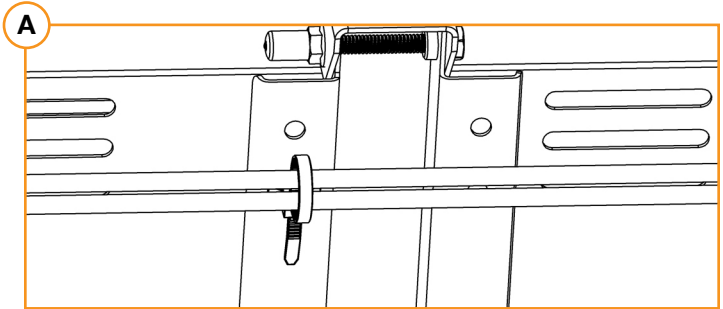

B. GROUNDING LUGS

Install Grounding Lugs as specified by engineered drawings. Use one of the four (4) grounding locations on each Ballast Tray, located at ends of Ballast Supports. Torque nut to 120 in-lbs and set screw to 84 in-lbs.

- ☑ Review [WEEB Compatibility Letter](#) for more information.

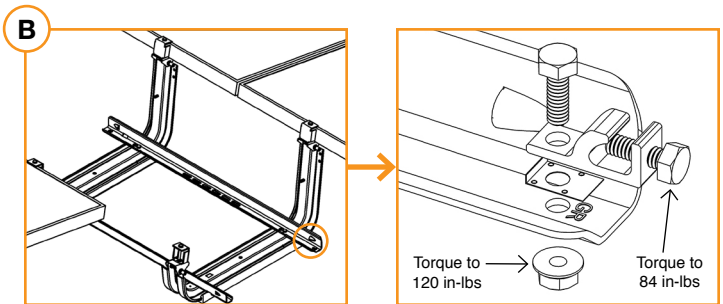

5. PLACE DEFLECTORS

A. REVIEW LAYOUT

Refer to engineering documents to determine locations.

B. WIND DEFLECTORS

Beginning at eastern edge of array, secure first Wind Deflector to Ballast Trays beneath last module in row with three (3) flange nuts. Torque nuts to 84 in-lbs.

Working west, place next deflector to overlap the prior. Secure deflector to Ballast Trays with two (2) flange nuts. Connect overlapping sections of deflectors with two (2) 1/4" self-drilling screws, using pilot holes on overlapping (or western) deflector. Torque until snug.

- ☑ If using a High Wind Deflector Kit, see [Page 8](#).
- ☑ It may be helpful to drill holes on underside deflector prior to installing screws.

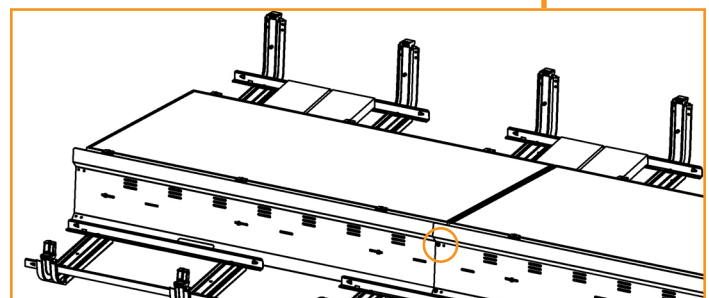
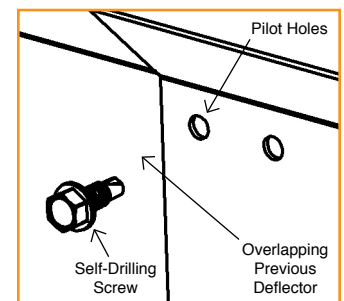
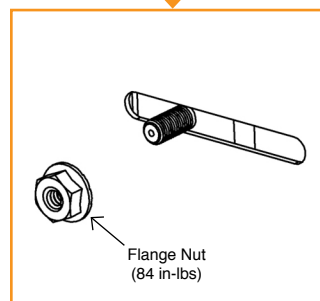
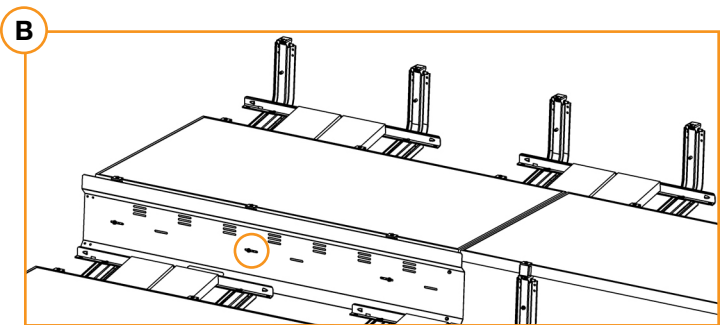

C. THERMAL EXPANSION

When there are twelve (12) or more deflectors, omit screws for thermal breaks. Wind Deflector groups should be no fewer than six (6) and no greater than eleven (11).

EW WIRE CLIP (OPTIONAL)

Wire Clips may be installed during or after modules. To install, simply press clip into lower mounting holes on Main Support of Ballast Tray. Bundle wire and clip to hold in place. Clips hold bundles up to 50 lbs and 1" in diameter.

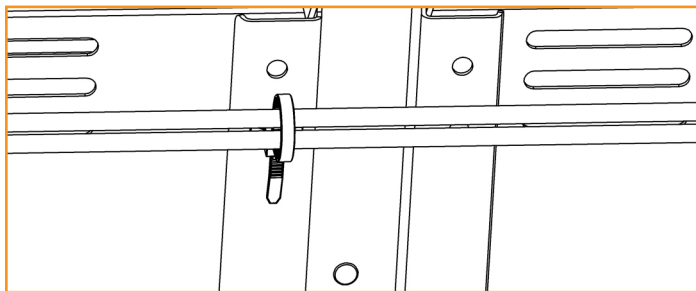

MICROINVERTER BRACKET (OPTIONAL)

Attach bracket to tray or deflector with two (2) 1/4"-20 x 3/4" hex bolts, nuts and washers. Attach microinverter to bracket with two (2) 1/4"-20 x 1" hex bolts, nuts and washers. Torque to 120 in-lbs. Ground as specified.

- ☑ Microinverter Bracket is compatible with Enphase Energy models: M190, M210, M215, M250 and D380; SolarEdge models: OP250-LV, OP300-MV, OP400-MV, PB250-AOB, PB350-AOB, PB250-TFI, and PB350-TFI; Power One models: MICRO-0.25-I-OUTD-US-208/240 and MICRO-0.3-I-OUTD-US-208/240; and Direct Grid Technologies models: DGM and DGA series.

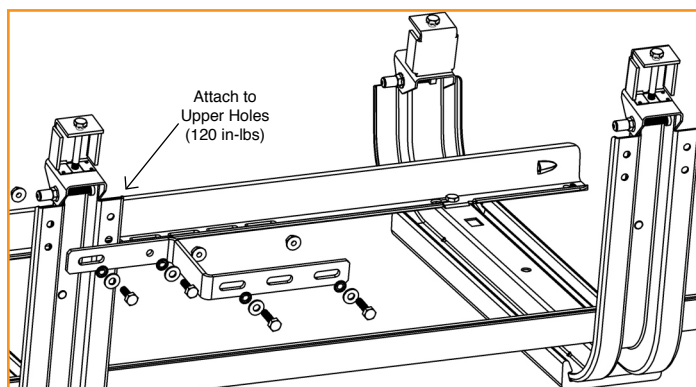

SEISMIC ANCHOR (OPTIONAL)

After installing system, determine and mark Seismic location. Line up bracket holes with Ballast Tray slots.

Seismic Anchor includes adapter bracket and [EcoFasten Eco-44R-6"](#). Connect bracket to installed Eco-44R-6" with two (2) 3/8" hex bolts. Torque to 204 in-lbs. Attach bracket to tray with four (4) 1/4" hex bolts. Torque to 120 in-lbs.

- ☑ Refer to engineering drawings for Seismic Anchor location(s).
- ☑ Comply with roofing manufacturer's warranty guidelines. Most manufacturers require inspections and certified installers.

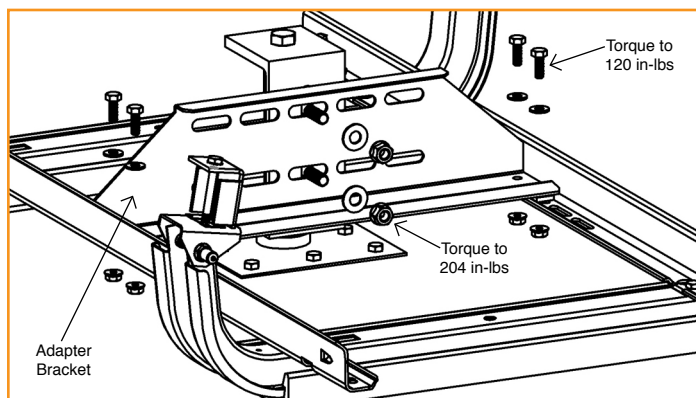

HIGH WIND DEFLECTOR KIT (OPTIONAL)

High Wind Deflector Kits secure deflectors together with four (4) 1/4" self-drilling screws. Drill screws in pilot holes until snug. Refer to [Page 5](#), for Wind Deflector instructions.

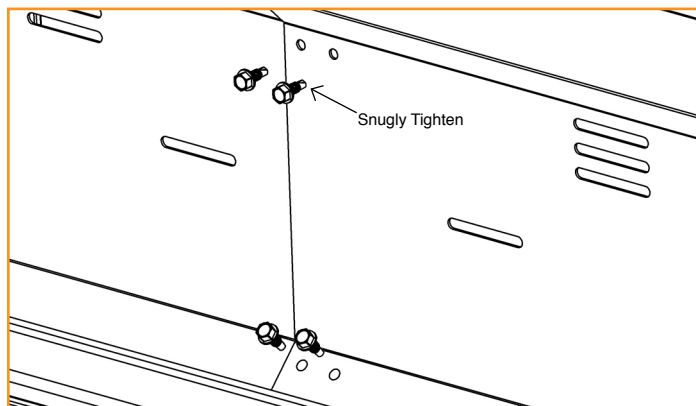

ROOF PADS (OPTIONAL)

Snap Roof Pads onto bottom of each of Main Support by placing Ballast Tray on pads and pushing down. Use two (2) pads per tray. Install prior to placing trays down on roof.

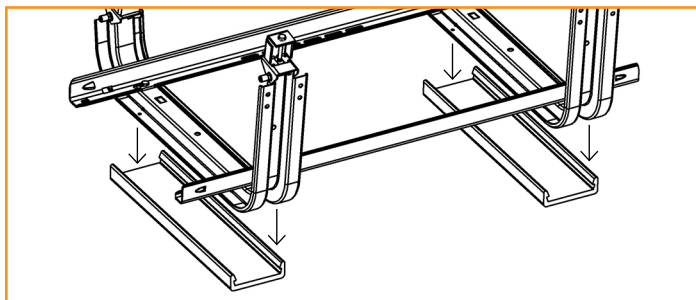

UNDER-MOUNTING TRAYS (OPTIONAL)

A. SOUTHERN TRAYS

Cut through tall side of Main Supports, between 0" and 4" above Ballast Support. Remove sharp remnants and loose material from cut ends with wire wheel. Apply rebar epoxy coating to cut ends, multiple times, and cure as specified. Set down cut trays in reverse direction, keeping centered on Baseline. Place ballast in each tray. Reverse direction of remaining plates and clamps. Install modules ([Page 4](#)).

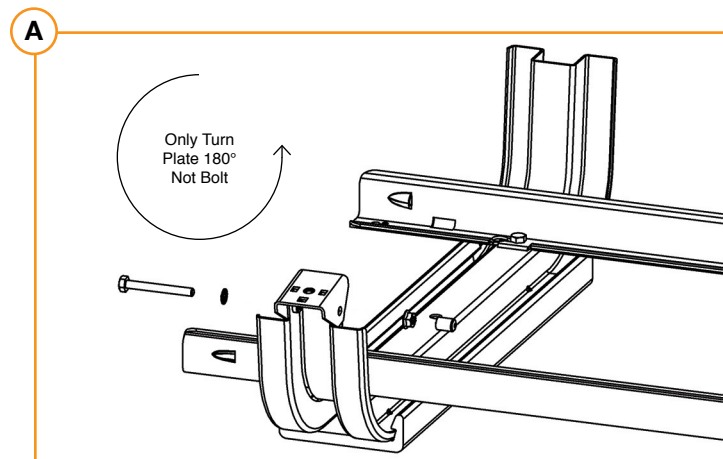

B. NORTHERN TRAYS

Place north row of Ballast Trays in reverse direction. Reverse direction of plates and clamps on tall side of Main Supports. Remove clamps on short side of Main Supports. Place ballast in each tray. Install modules ([Page 4](#)).

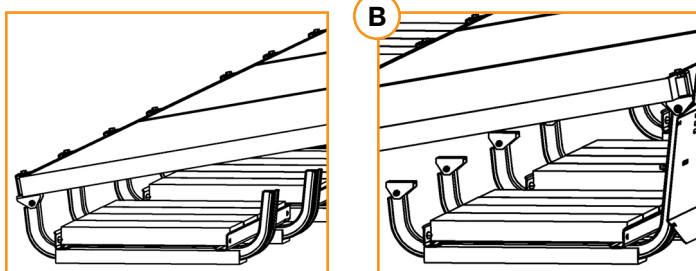

WARRANTY

Effective for IronRidge, Inc. (“IronRidge”) mounting structure components (“Products”) manufactured after April 1st, 2012, IronRidge provides the following warranties, for Products installed properly and used for the purpose for which the Products are designed:

- finishes shall be free of visible defects, peeling, or cracking, under normal atmospheric conditions, for a period of three (3) years from the earlier of (i) the date of complete installation of the Product or (ii) thirty days after the original purchaser’s date of purchase of the Product (“Finish Warranty”);
- components shall be free of structurally-related defects in materials for a period of ten (10) years from the earlier of (i) the date of complete installation of the Product or (ii) thirty days after the original purchaser’s date of purchase of the Product;
- components shall be free of functionally-related manufacturing defects for a period of twenty (20) years from date of manufacture.

The Finish Warranty does not apply to: (a) surface oxidation of the galvanized steel components or any foreign residue deposited on Product finish; and (b) Products installed in corrosive atmospheric conditions, as defined solely by IronRidge; corrosive atmospheric conditions include, but are not limited to, conditions where Product is exposed to corrosive chemicals, fumes, cement dust, salt water marine environments or to continual spraying of either salt or fresh water. The Finish Warranty is VOID if (c) the practices specified by AAMA 609 & 610-02 – “Cleaning and Maintenance for Architecturally Finished Aluminum” (www.aamanet.org) are not followed by Purchaser for IronRidge’s aluminum based components; and (d) if the practices specified by ASTM A780 / A780M - 09 “Standard Practice for Repair of Damaged and Uncoated Areas of HotDip Galvanized Coatings” are not followed by Purchaser for IronRidge’s galvanized steel-based components.

The warranties above do not cover any parts or materials not manufactured by IronRidge, and exclude nonfunctionally-related defects, as defined solely by IronRidge. The warranties do not cover any defect that has not been reported to IronRidge in writing within twenty (20) days after discovery of such defect.

In the event of breach of or non-compliance with the warranties set forth above, IronRidge’s sole obligation and liability, and the sole and exclusive remedy for such breach or non-compliance, shall be correction of defects by repair, replacement, or credit, at IronRidge’s sole discretion. Such repair, replacement or credit shall completely satisfy and discharge all of IronRidge’s liability with respect to these warranties.

Refurbished Product may be used to repair or replace the defective components. Transportation, installation, labor, or any other costs associated with Product replacement are not covered by these warranties and are not reimbursable. These warranties additionally do not cover (a) normal wear, or damage resulting from misuse, overloading, abuse, improper installation (including failure to follow professional instruction and certification), negligence, or accident, or from force major acts including any natural disasters, war or criminal acts; and (b) Products that have been altered, modified or repaired without written authorization from IronRidge or its authorized representative; and (c) Products used in a manner or for a purpose other than that specified by IronRidge. A formal document proving the purchase and the purchase date of the Product is required with any warranty claim.

Except as set forth above, IronRidge sells the Products on an “AS IS” basis, which may not be free of errors or defects, and ALL EXPRESS OR IMPLIED REPRESENTATIONS AND WARRANTIES, INCLUDING ANY WARRANTIES OF MERCHANTABILITY, FITNESS FOR A PARTICULAR PURPOSE, QUALITY, WORKMANLIKE EFFORT, CORRESPONDENCE TO DESCRIPTION, DESIGN, TITLE OR NON-INFRINGEMENT, OR ARISING FROM COURSE OF DEALING, COURSE OF PERFORMANCE OR TRADE PRACTICE, ARE HEREBY DISCLAIMED.