

Attn: Corey Geiger, Global COO, Esdec Inc.

Date: March 4th, 2021

Re: Structural Certification for QuickMount *L-Mount* with Open-End Slot

This letter certifies the structural capacities of QuickMount *L-Mount* with open-end slot for use as a roof attachment for flush mounted PV solar systems. The *L-Mount* consists of an extruded aluminum L-foot with a vertical open-end slot, positioned above a 9" x 12" aluminum flashing. The *L-Mount* is fastened to an underlying roof rafter using a 5/16" x 4" lag screw or 5/16" x 4.5" structural screw. Full assembly details and component dimensions are shown in Exhibit EX-0020.

The structural capacities of *L-Mount* are reviewed along three respective load directions including uplift, lateral parallel to the rafter, and lateral perpendicular to the rafter. The capacity ratings are based on structural load tests performed using a Universal Instron Test Unit according to ASTM D1761-20 "Standard Test Methods for Mechanical Fasteners in Wood and Wood Based Materials". For each load test an *L-Mount* was installed onto a sample roof deck composed of 7/16" OSB Board over 2x4 rafters as shown in Figure 1. The moisture content and the specific gravity of the rafters were measured per ASTM D2395-17 "Standard Test Methods for Density and Specific Gravity (Relative Gravity) of Wood and Wood-Based Materials". The recorded moisture content of the rafters among all sample roof decks is between 10% and 14%. For each load test, the point load was placed at the highest position allowed at the open-end slot.

The failure observed under the uplift load was pull-out of the lag screw and structural screw at the peak load of 2693 lbs. and 2344 lbs., respectively. The results are the average of five (5) tests provided to each fastener condition. With a safety factor of 3.0 applied to the wood-based fastener pull-out, **the allowable uplift capacity is 898 lbs. for *L-Mount* using the lag screw, and 781 lbs. for *L-Mount* using the structural screw.** The above allowable capacity is applicable to roof decks with a rafter specific gravity greater than or equal to 0.50, which was recorded in the uplift load tests. For rafters with a lower specific gravity, the allowable uplift capacity shall be adjusted as described in Footnote 8 of Table 1.

For the lateral load tests, two load directions (parallel or perpendicular to rafter) and two *L-Mount* orientations (vertical face of L-foot normal to the rafter or parallel to the rafter) were tested. The critical failure mode, which results in the lowest allowable lateral capacity, was observed be the L-foot yielding at the base of its vertical leg under a perpendicular lateral load. The average of the yield loads from five (5) lateral load tests is 425 lbs. With a safety factor of 1.65 per ADM-2015 for the aluminum yielding, **the allowable lateral capacity is 258 lbs. for loads parallel or perpendicular to the rafter.** The specified allowable lateral capacity shall be used when the supporting rafter has a specific gravity not less than 0.40, which was the average density recorded in the lateral load tests.

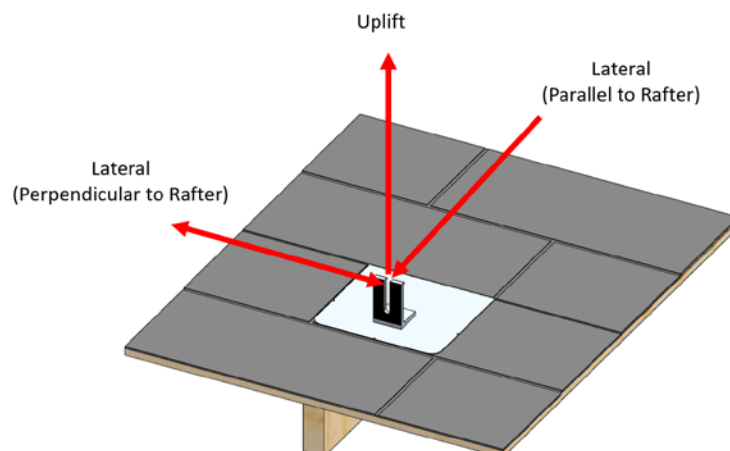

Figure 1: L-Mount Assembly and Applied Loading Directions (using lag screw or structural screw).

Table 1: QuickMount L-Mount Allowable Capacities ⁽¹⁾⁽²⁾						
Load Direction	Test Quantity	Average Peak Load at Failure (lbs)	Deviation of Test Results ⁽⁵⁾	Critical Failure Mode	Safety Factor ⁽⁶⁾	Allowable Capacity (lbs) ⁽⁷⁾
Uplift (lag screw) ⁽³⁾⁽⁸⁾	5	2693	6.9%	Lag screw pull-out	3.0	898
Uplift (structural screw) ⁽³⁾⁽⁸⁾	5	2344	2.8%	Structural screw pull out	3.0	781
Lateral ⁽⁴⁾	5	425	5.9%	L-foot vertical leg yielding	1.65	258

Table 1 Footnotes:

(1) Table values apply to QuickMount L-Mount with open-end slot.

(2) Capacities apply to rafter size of 2x4, a deck thickness of 7/16" or greater, and lag screws or structural screws secured within the center 1/3 of rafter width with a minimum 2.5" end distance. Rafters should be in sound structural condition with no sign of rot or decay.

(3) The uplift direction is the upward direction perpendicular to the roof surface.

(4) The allowable lateral capacity is applicable to the lateral loads parallel or perpendicular to the rafter and to the L-foot orientations when the vertical face of the L-foot is normal to the rafter or perpendicular to the rafter. The minimum required rafter specific gravity for the lateral capacity is 0.40.

(5) Deviation reflects the variance of the highest or the lowest test value from the group mean for the respective load direction.

(6) Safety Factor is associated with the respective failure modes recorded and determined per NDS-2018 or ASTM-7147.

(7) Allowable capacity is equal to Average Peak/Yield Load at Failure divided by its associated Safety Factor.

(8) The uplift allowable capacity in Table 1 applies to rafters with a specific gravity (G) of 0.50 or higher. For a wood species with specific gravity lower than 0.50 the allowable uplift capacity shall be adjusted by a factor of $\left(\frac{G}{0.50}\right)^{\frac{3}{2}}$ per National Design Specification (NDS-2018) Eq. (12.2-1). Results of common wood species are adjusted and provided in Table 2 below.

Table 2: QuickMount L-Mount Allowable Uplift Capacities for Rafters with G Less Than 0.50			
Wood Species	Specific Gravity of Chosen Rafter (G)	Allowable Uplift Capacity with Lag Screw (lbs)	Allowable Uplift Capacity with Structural Screw (lbs)
Douglas Fir-South	0.46	792	689
Hem-Fir (North)	0.46	792	689
Hem-Fir	0.43	716	623
Spruce-Pine-Fir	0.42	691	602

Sincerely,



Gang Xuan, SE
Senior Structural Engineer

EXHIBIT: EX-0020

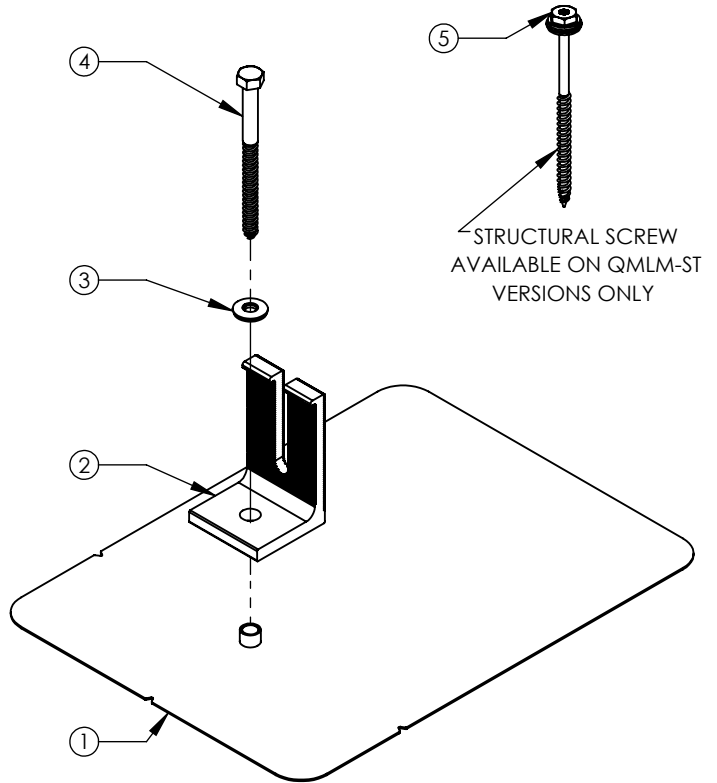
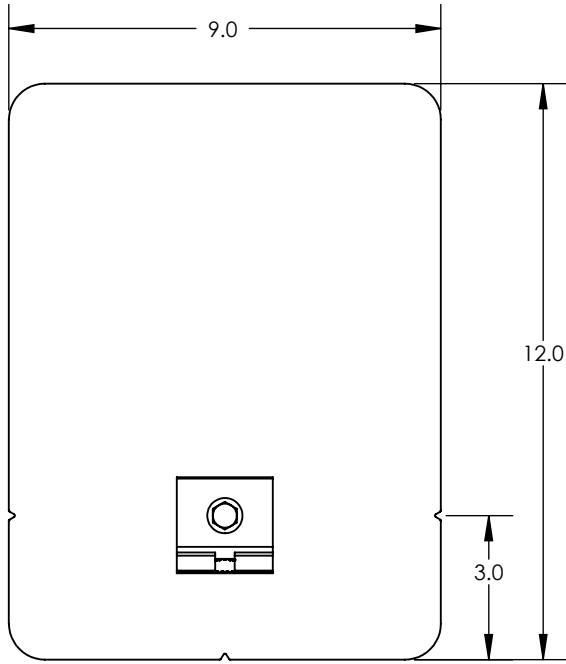

L-MOUNT

(LAG SCREW)

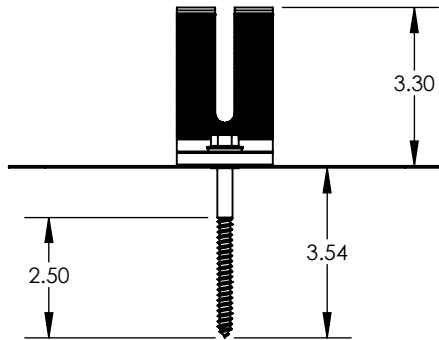

L-MOUNT

(STRUCTURAL SCREW)

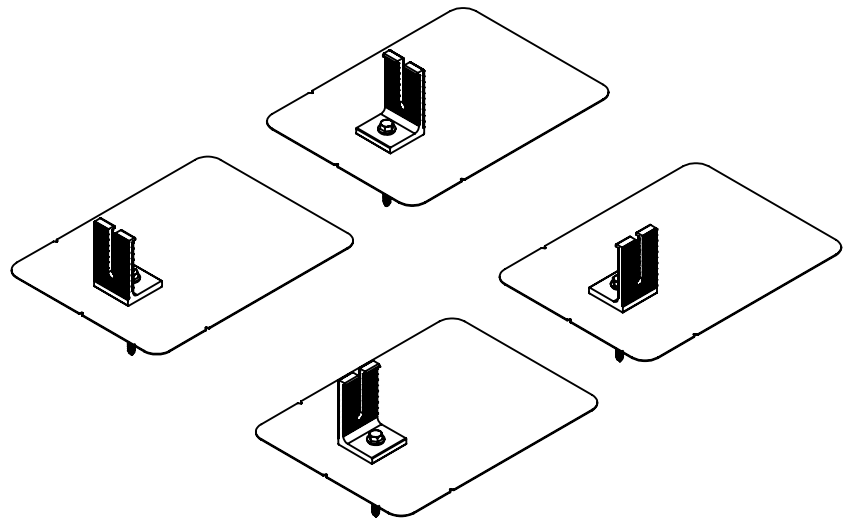
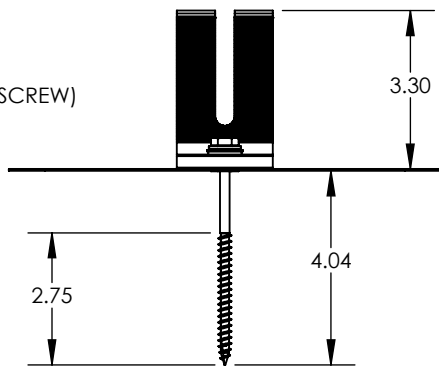

L-MOUNT CAN BE INSTALLED IN ANY ORIENTATION AS SHOWN ABOVE

ITEM NO	DESCRIPTION
1	FLASHING SUB-ASSEMBLY, 9X12 FLASHING, .437 X .350 HEX FLANGE FASTENER, MILL/BLACK
2	OPEN SLOTTED L-FOOT, MILL/BLACK
3	WASHER, SEALING, 5/16" ID X 3/4" OD, EPDM BONDED SS
4	LAG SCREW, HEX HEAD, 5/16 X 4", 18-8 SS
5	STRUCTURAL SCREW, T-30 HEX WASHER, 5/16" X 4-1/2", 18-8SS

IRONRIDGE

ASSY, L-MOUNT
DWG. NO. EX-0020